



## Injection Molding Startup Procedure For Granular Polyester Molding Compounds

Before setting a mold into a press, it is necessary to estimate an appropriate press size for that mold. To determine the press size, multiply the projected area of the part at the parting line by 27.6 MPa (4,000 psi). For injection/compression molds that are to be run in toggle style presses, multiply the projected area by 41.4 MPa (6,000 psi). In other words, the mold must fit between the tie bars, and the clamping tonnage should be approximately the amount determined by the above formula. A press that lacks sufficient clamp tonnage will result in parts that are heavily flashed and not well packed. These parts may have less than data sheet values physically and electrically and their appearance may also be questionable. However, if a mold that is designed to run in a press with a clamp tonnage of 75 tons is set in a press with a clamp tonnage of 400 tons, it is quite possible that significant damage will be done to the mold itself.

In addition to reviewing the physical size of the mold, it should be determined if the shot size is within the press capacities. Typically, between 20% and 80% of the total shot capacity of the press should be used. If too little of the shot capacity is used, there will be plasticized material in the barrel that will increase in temperature until it cures in the nozzle and prevents material from being injected into the mold. At the other extreme, a small difference in the powder properties or the specific gravity from one batch to the next can result in not being able to continuously fill the mold with sufficient material to pack out the parts.

Once the mold and press have been matched, a check should be made to ensure that the nozzle of the press is the correct size and shape to fit the sprue bushing. This means that if the sprue bushing has a 19 mm ( $\frac{3}{4}$ " ) spherical radius, then the nozzle tip should have a matching 19 mm ( $\frac{3}{4}$ " ) spherical radius. In addition, the orifice of the sprue should always be at least 1 mm ( $\frac{1}{32}$ " ) larger than that of the nozzle. The primary reason for a sprue sticking in the stationary half of the mold is that the nozzle orifice wears and becomes larger than that of the sprue, making it difficult or impossible to pull the end of the sprue through the sprue bushing. Unless specified otherwise, sprue bushings are generally made of soft steel that is not hardened and wears away fairly easily, especially if an abrasive material like a glass reinforced molding material is being processed. Nozzles designed for thermoset materials should allow the screw tip to come forward to a point that is 13 mm ( $\frac{1}{2}$ " ) from the end of the nozzle. The smallest diameter of the nozzle orifice should be located at this same point. The nozzle orifice should be tapered so the orifice diameter at the open end is 0.25 mm (0.010" ) larger than it started as illustrated in this drawing.

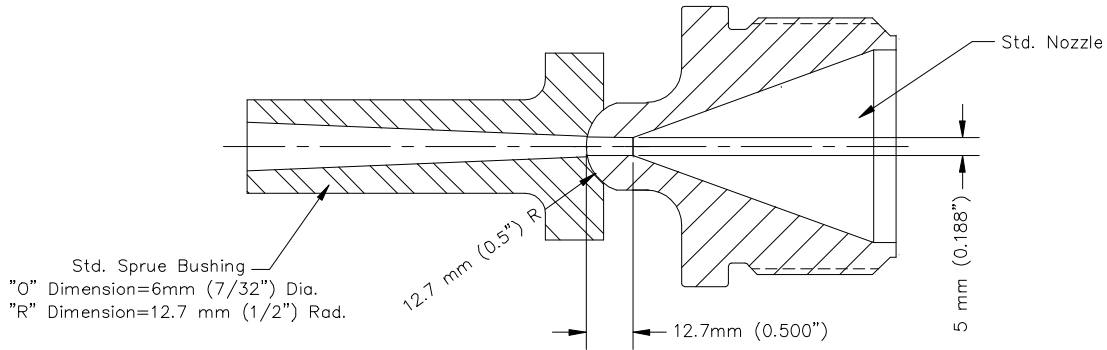

Once a mold has been matched with a press and is installed in that press, a standard procedure should be followed to begin molding parts. Following a written procedure each time a mold is installed makes it easier for the press operators, by helping to minimize potential accidents and prevent the omission of any procedural steps. After the mold is set, the following startup procedure can be implemented:

1. Turn on the heat and frequently check the temperature of the molding surfaces with a calibrated pyrometer and surface probe. Typically, start with a mold temperature of 163°C - 182°C (325°F - 360°F). **PLEASE NOTE:** The temperature should be relatively uniform across the entire molding surface.
2. Set the temperatures of the water jackets. Typically, the front zone should start at 85°C - 93°C (185°F - 200°F) and the rear zone should start at 49°C - 71°C (120°F - 160°F).
3. With the pyrometer and surface probe, check the "in" and "out" connections of each zone of the water heater to confirm that the actual water temperatures are close to the set temperature. There can be some variance from the set temperature, but a difference of 5°C - 10°C (10°F - 20°F) should be investigated. The problem may be calibration or something more serious such as a blocked water line. Of particular concern would be a situation where the "in" and "out" connections of the same zone are significantly different in temperature. This could be an indication that there is a blockage in the water jacket.
4. The next step in the setup is to set the mold opening distance. This distance is important because if a mold opens too far, it can slow the overall cycle, which will result in fewer shots per hour. If a mold does not open far enough, the removal of the parts and runner may be difficult. This can effect cycle time and may also cause damage to the parts.
5. At the same time that the mold open distance is being established, the ejector stroke length should also be set. The ejection stroke should be long enough to insure that the parts are ejected from the cavity. A full ejection stroke that extends to the stops is not always necessary. A shorter ejection stroke can sometimes be used to help reduce the mold open time between shots.

6. Set the screw speed, which in most cases should be 60 rpm or less. A faster speed may not allow the material to be picked up and the result will be the same as running at a slower speed. In addition, running at a slower speed usually produces a more uniform stock temperature and a more consistent shot weight.
7. Set the back pressure for 0.3 MPa (50 psi) and air purge a couple shots. Check the stock temperature of the purged material from the third shot with a calibrated pyrometer and needle probe. The stock temperature is measured by air purging a shot of material and forming it into a ball, which is then checked after probing it 2 or 3 times using the needle probe of the pyrometer. The temperature should be 93°C - 100°C (200°F - 212°F). **NOTE:** At this point, the stock temperature will most likely be about 88°C - 93°C (190°F - 200°F) since you are just starting the process. It will take several molding cycles before it actually reaches between 93°C - 100°C (200°F - 212°F).
8. PLEASE NOTE: **NEVER** breathe the mold when molding PLENCO granular polyester molding compounds. The reason for this is breathing will allow air to enter the mold which will stop the resin reaction before the material is completely cured. To prevent this from occurring, molds built for this type of molding compound are normally vacuum vented.
9. Before injecting the material for the first shot, the throttle or injection speed should be completely open. The amount of vacuum being pulled in the mold should be checked to insure it is at least 21" Hg and then set the amount of injection delay time needed to allow the vacuum system to achieve it. The shot size should be adjusted so there will be less than a complete shot. The injection pressures should also be set so the material will fill the cavities in 3 - 6 seconds. It normally is better to begin with a less than full shot (about  $\frac{3}{4}$  to  $\frac{7}{8}$  of a complete shot) and gradually work up to full shots. This way, there is less chance of damaging the mold by bending or breaking core pins and it will show if the filling of the cavities is balanced.
10. Just prior to injecting the first shot, the mold should be waxed. Carnuba wax works well for this purpose. To wax a mold, melt the wax on the molding surface and with the aid of a small natural bristle paintbrush, spread it over the entire molding surface, getting it into every pocket and corner. Remove any excess wax from the mold surface.
11. The molding parameters should be adjusted to produce good parts from all cavities, each shot. Typically, the injection time should be 3 - 6 seconds. The primary injection pressure should be in the range of 6.2 - 11.0 MPa (900 - 1,600 psi) while the secondary injection pressure should be set at  $\frac{1}{2}$  to  $\frac{2}{3}$  of the primary injection pressure. After an acceptable molding process is established, it should be capable of continuing without change for many hours.
12. To insure that typical batch to batch variations of the material will not affect the processing setup, 1.4 MPa (200 psi) is added to the primary injection pressure. The throttle or injection speed is adjusted so it takes the same length of time to inject the material. Example: With the throttle fully opened the injection time was taking 7 seconds. With the injection pressure increased by 1.4 MPa (200 psi), the throttle is adjusted so it still takes 7 seconds to fill the mold.

13. Because a reciprocating screw does not pick up exactly the same amount of material every cycle, it is a good practice to use a cushion when injection molding thermoset materials. To establish a cushion, 3 mm ( $\frac{1}{8}$ " ) is added to the injection stroke and at the same time the switch to secondary pressure or holding pressure is set at 6 mm - 10 mm ( $\frac{1}{4}$ " -  $\frac{3}{8}$ " ) from the end of the stroke. Machines that use timers are more difficult to control because the injection time will vary from shot to shot. As a result, the switch from primary pressure may not be timed correctly, which can adversely affect the parts. **Note:** The screw may not stop its forward motion when it reaches the cushion. This is not unusual and sometimes the screw will continue forward until it reaches the end of the barrel.
14. Once the material has been injected into the mold, it is held under pressure until the gate is well cured. The time it takes the gate to cure can vary and the larger the gate opening the longer it will take to cure. The most common indication of an undercured gate is depressions or sink marks at or near the gate.
15. After the gates have cured, the screw can be run to plasticize material for the next shot. Typically, the screw should finish running one or two seconds before the press opens to eject the parts from the present shot. If the screw is returning too early, the screw run time should be delayed. Once the material is plasticized, the amount of time the next shot of material is held in the barrel before it is injected should be kept to a minimum.
16. Upon ejection from the mold, the sprue should have a soft bulbous tip. If it does not, too much heat is being transferred from the sprue bushing to the nozzle and the probability of nozzle freeze off increases significantly. In order to prevent this, we suggest doing one of the following:
  - Install a device to gently blow a continuous stream of air over the tip of the nozzle.
  - Install a nozzle that has a smaller radius than the sprue bushing.
  - Insert a piece of **corrugated** cardboard between the nozzle and sprue bushing to insulate the nozzle.

Please note, we do not generally encourage the use of a sprue break, as it does not pull the tip and can lead to other processing problems.

Date Printed: January 29, 2009

Date Revised: January 9, 2009

Supersedes Revision Dated: April 10, 2001

This information is suggested as a guide to those interested in processing Plenco Thermoset molding materials. The information presented is for your evaluation and may or may not be compatible for all mold designs, runner systems, press configurations, and material rheology. Please feel free to call Plenco with any questions about PLENCO molding materials or processing and a Technical Service Representative will assist you.